

Silicon NPN Power Transistors

2SC3420

DESCRIPTION

- With TO-126 package
- High DC current gain
- Low saturation voltage
- High collector power dissipation

APPLICATIONS

- Storobo flash applications
- Medium power amplifier applications

PINNING

PIN	DESCRIPTION
1	Emitter
2	Collector;connected to mounting base
3	Base

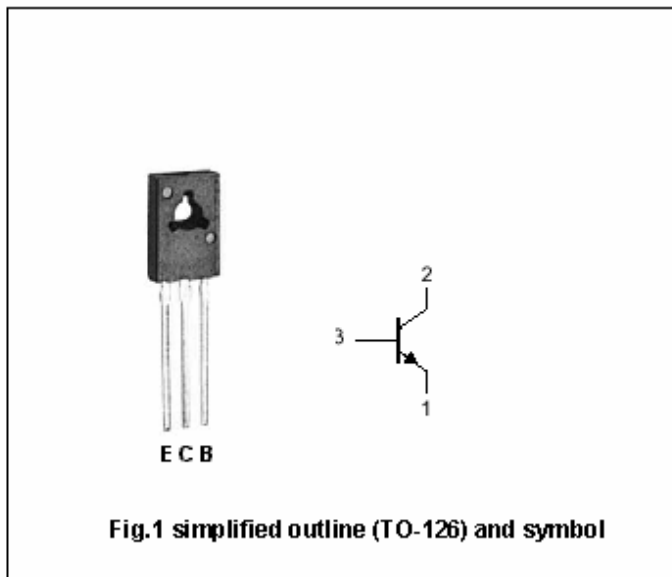

Absolute maximum ratings(Ta=25°C)

SYMBOL	PARAMETER	CONDITIONS	VALUE	UNIT
V _{CB0}	Collector-base voltage	Open emitter	50	V
V _{CEO}	Collector- emitter voltage	Open base	20	V
V _{EBO}	Emitter-base voltage	Open collector	8	V
I _C	Collector current		5	A
I _{CM}	Collector current-peak		8	A
I _B	Base current		1	A
P _C	Collector power dissipation	T _a =25°C	1.5	W
		T _C =25°C	10	
T _J	Junction temperature		150	°C
T _{stg}	Storage temperature		-55°C+150	°C

Silicon NPN Power Transistors

2SC3420

CHARACTERISTICS

T_j=25°C unless otherwise specified

SYMBOL	PARAMETER	CONDITIONS	MIN	TYP.	MAX	UNIT
I _{CBO}	Collector cutoff current	V _{CB} =40V; I _E =0			100	nA
I _{EBO}	Emitter cutoff current	V _{EB} =8V; I _C =0			100	nA
V _{(BR)CEO}	Collector-emitter breakdown voltage	I _C =10mA ; I _B =0	20			V
V _{CEsat}	Collector-emitter saturation voltage	I _C =4A ; I _B =0.1A			1	V
V _{BE}	Base-emitter voltage	I _C =4A ; V _{CE} =2V			1.5	V
h _{FE-1}	DC current gain	I _C =0.5A ; V _{CE} =2V	140		600	
h _{FE-2}	DC current gain	I _C =4A ; V _{CE} =2V	70			
C _{Ob}	Output capacitance	I _E =0; V _{CB} =10V; f=1MHz		40		pF
f _T	Transition frequency	I _C =0.5A ; V _{CE} =2V,		100		MHz

◆ h_{FE-1} Classifications

Y	GR	BL
140-240	200-400	300-600

Silicon NPN Power Transistors

2SC3420

PACKAGE OUTLINE

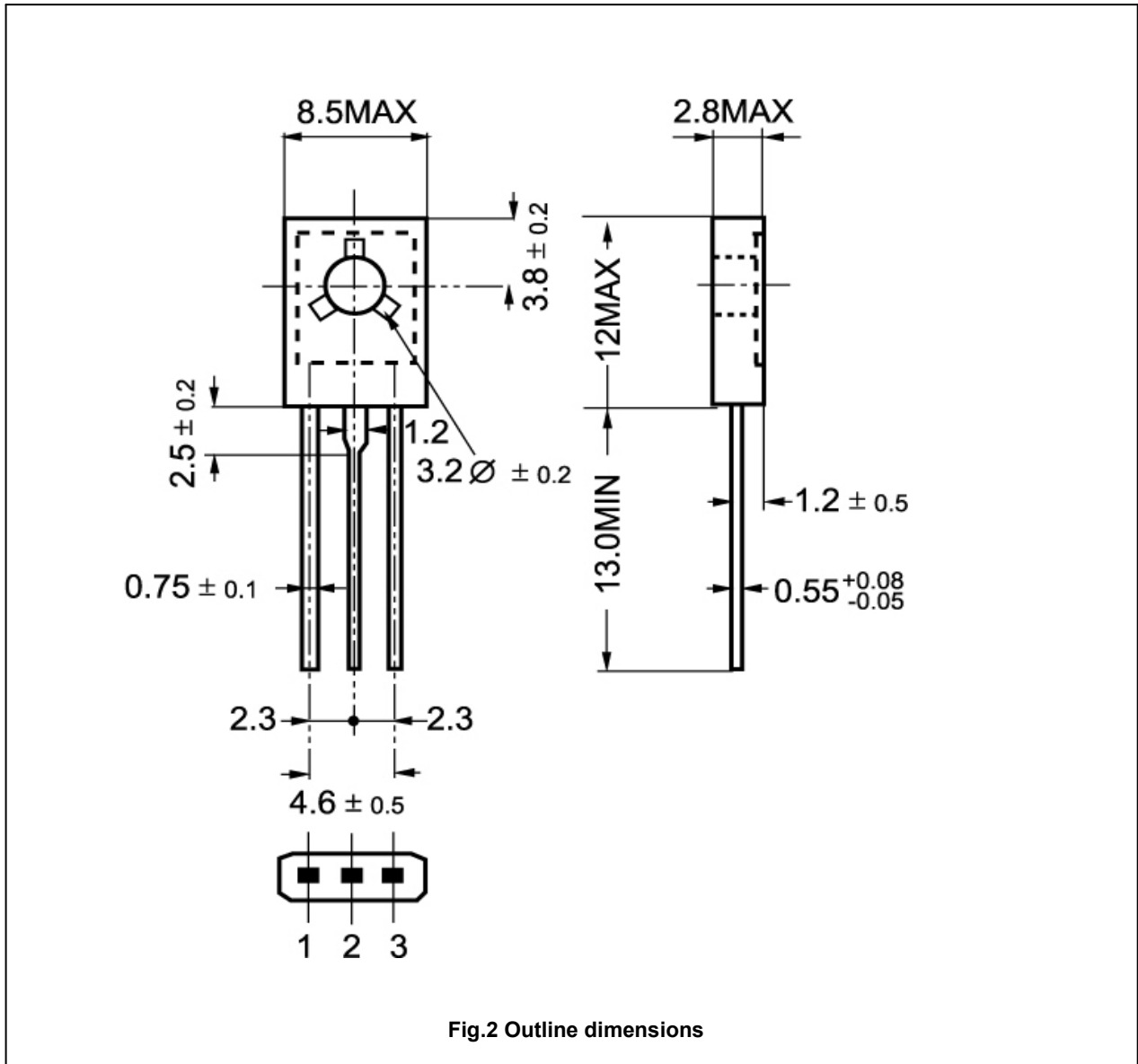

Silicon NPN Power Transistors

2SC3420

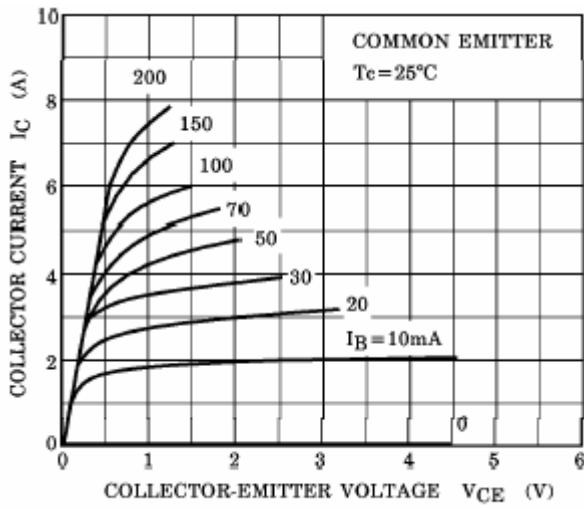

Fig.3 Static Characteristic

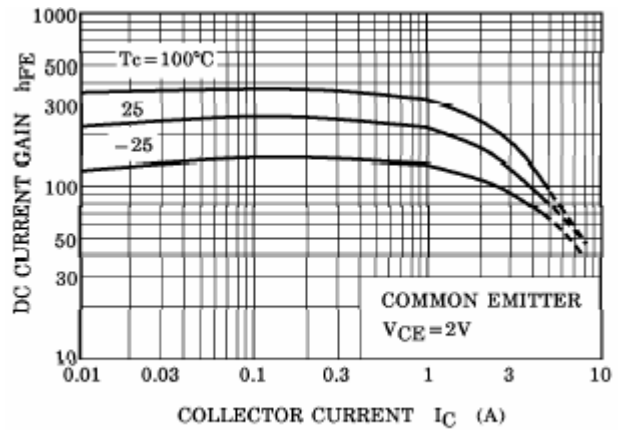

Fig.4 DC current Gain

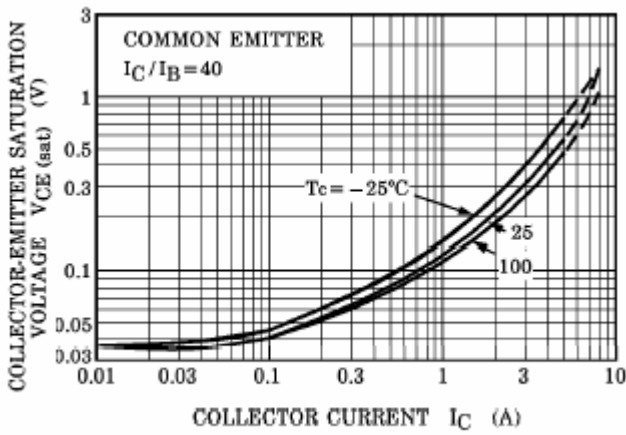

Fig.5 Collector-Emitter Saturation Voltage

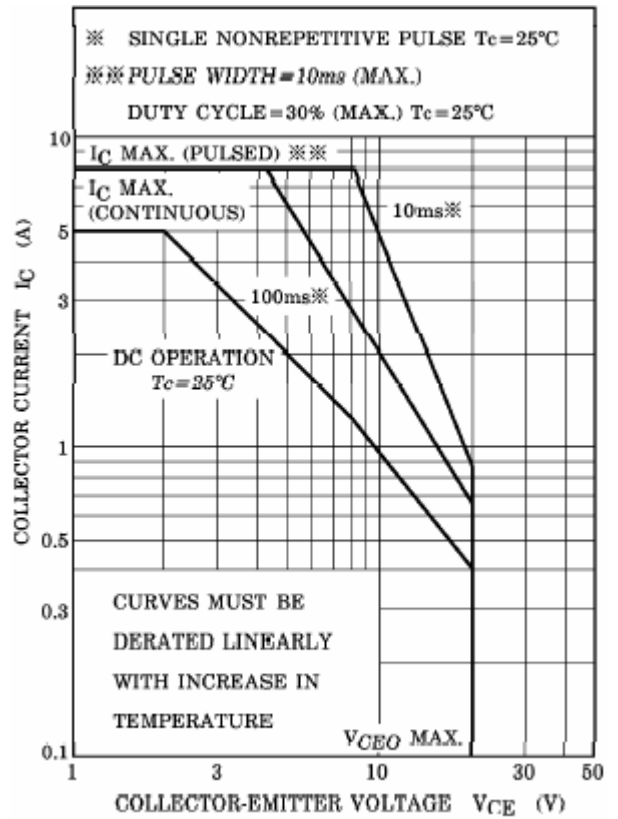

Fig.6 Safe Operating Area